

Pro Series Pop-Up Canopy Truss Pop-Up 10 x 20 ft. / 3 x 6,1 m



Bigger Pop-Up. Delivers 200 Sq. Ft. / 61 Sq. M. of Coverage!

- The biggest pop-up on the market. The new Pro Series 10 x 20 ft. / 3 x 6,1 m Truss Top Pop-Up combines expansive triple truss design, quality construction and show room good looks in one great to go unit.
- Sturdy beam welded tube steel design with high performance synthetic joint components is bonded with Dupont™ thermoset baked on powder coat. Prevents chipping, peeling, rust and corrosion.
- Innovative triple truss design adds strength and stability.
- Four point adjustable legs



- Wide based foot pads on every leg ensure a rock solid base and easy access to secure anchor points.
- Polyurethane coat lining is double stitched and sealed for optimal water resistance and drip-free seams.
- Polyester fabric cover is UV treated inside and out with added fade blockers, anti-aging, anti-fungal agents, resulting in a cover that withstands the elements.
- Wheeled storage bag allows for convenient transport and storage of canopy.

Great For: vendor tents, classic car shows, decks, patios, backyard events, or sporting or special events.

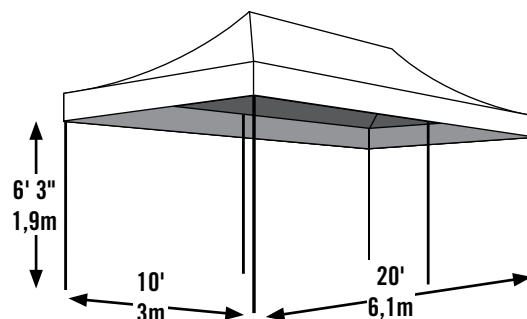

We've Got You Covered.™
North America's #1 Shelter Manufacturer.

Model #22535

Package Includes:

- (1) 10 x 20 ft. / 3 x 6,1m white collapsible steel frame
- (1) One-piece blue polyester cover with full valance
- (6) Temporary spike anchors
- Wheeled storage bag
- Easy step-by-step instructions

Packaging Specifications:

- Container qty: 340
- Total weight: 105 lbs. 47,5 kg
- Box dimensions:
65 x 16.1 x 9.5 in.
165 x 41 x 24 cm

