

SUPER MAX Canopy Series

10' x 20' SUPER MAX 8-Leg Canopy



The Best Built 10' x 20' Canopy - Seasonal Shelter.

- Our most sturdy 2" frame canopy, the 10' x 20' SUPER MAX 8-Leg delivers rock solid seasonal protection for vehicles, backyard events, camping areas or special events.
- Our SUPER MAX Canopy is built only using high grade steel. Every frame pipe and connector is subjected to a proprietary 13 step Rhino Shield surface preparation process.
- Professional grade 2" all steel frame, bonded with Dupont™ thermoset baked on powder-coated finish that holds on tight and prevents chipping, peeling, rust and corrosion.
- Advanced engineered, triple-layer, chemically heat bonded enhanced weave, rip-stop, 100% waterproof, polyethylene cover. UV-treated inside and out with added fade blockers, anti-aging, anti-fungal agents resulting in a fabric cover that withstands the elements.
- Quick and easy set up built in with slip together swedged tubing and Patented Twist Tite™ tensioning squares up frames and tightens down covers for a clean, finished look.



Great For: Vendor canopy, camping, decks/patios, pool areas and vehicle storage.

- One full-color graphic retail package.



We've Got You Covered.™
North America's #1 Shelter Manufacturer.

Model #23571

Package Includes:

- (1) 10' x 20' 8-Leg, 2" Diameter, powder-coated frame
- (1) One-piece, full valance, white, polyethylene, fitted cover
- SL Bungee fasteners
- (8) Foot plates - white
- Temporary spike anchors
- Easy Step-by-Step Instructions

Packaging Specifications:

- Pallet qty: 10
- Container qty: 270
- Total weight: 145 lbs.
- Box dimensions: 78.7 x 18.7 x 8 in.

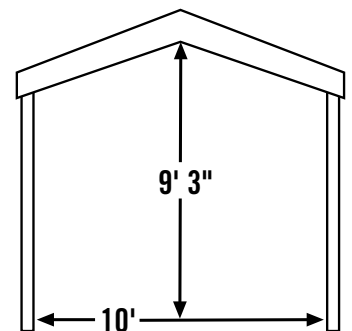

Shelters of New England • 251 West Hollis St. • Nashua, NH 03060
603-886-2701 • www.sheltersofne.com